

FEATURES

500mW Amplifier:

Frequency 800Mhz to 1000Mhz

High Output Power at 869Mhz

+27dBm at +5V

+25dBm at +3.6V

+3.6V to +5.5V Single Supply Operation

Automatic Power-Up/Power-Down Ramp

Direct On/Off Keying (OOK) without intersymbol interference

Or VCO Pulling

47% efficiency

<15uA Supply Current in Shutdown Mode

Automatic Shutdown in RX Mode

Switch TX/RX:

Transmit / Receive GaAs MESFET Switch

1.4dB insertion Loss at 869Mhz

24dB Crosstalk Isolation at 869 Mhz

+27dBm Output P1dB

Dual Switch for single port TX/RX transceiver

General:

Protection for Reverse Polarity

High quality MCX50 RF connectors

Small dimensions: 28x29x5mm

TYPICAL APPLICATIONS

868 – 900Mhz ISM-Band Applications

Wireless Data Network

Wireless Computer Peripherals

Wireless Security Systems

Radio Control Peripherals

Radio Control RC, FPV & UAV airplane Systems

Commercial and Consumer Systems

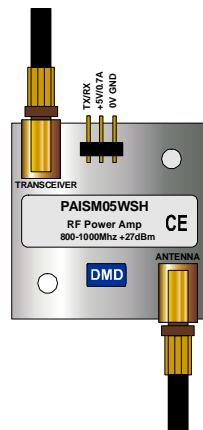

Wireless Systems

PAISM05WSH



27.7 x 28.6 x 5mm

The PAISM05WSH low-voltage, silicon RF power amplifier (PA) is designed for use in the 700-1000MHz frequency band. It operates directly from a single +3.0V to +5.5V supply, making it suitable for use with 3-cell NiCd or 1-cell Li-Ion batteries. The device delivers +28dBm (600mW) typical output power from a +5V supply or +25dBm from a +3V supply.

This last stage delivers 28dBm to a 50Ω load. It operates in Class E to achieve a high power-added efficiency (PAE). 50 Ω antenna or proper output matching, is required for optimal output power

The PAISM05WSH's is bi directional. At +28dBm output power, efficiency is typically 46%. An additional power-saving feature is a auto shutdown in RX mode, that typically reduces supply current below 1μA.

A key feature of this PA is its autoramping capability. During turn-on and turn-off periods, the RF envelope is controlled to approximate a raised cosine on the rising and falling edge, thereby minimizing transient noise and spectral splatter.

The PAISM05WSH is intended for use in constant envelope applications such as AMPS, two-way paging, FSKbased communications or Radio Control FPV / UAV airplane systems in the 868Mhz for Europe and 915MHz for EEUU, ISM bands.

The PAISM05WSH is designed for use with single port transceivers with a dual Transmit / Receive GaAs MESFET Switch with a CMOS logic driver for the control input.

Signal input and output use MCX50 connectors to facilitate the connection of RF equipment.

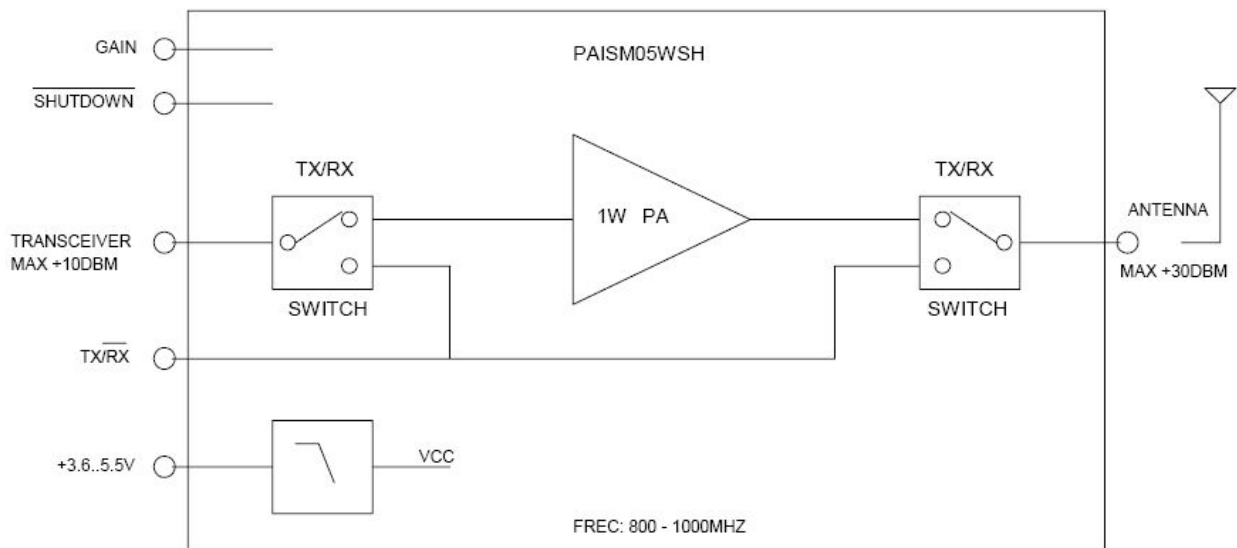

Quick Start

The PAISM05WSH is fully assembled and factory tested. Follow the instructions in the *Connections and Setup* section for proper module evaluation.

Test Equipment Required

This section lists the recommended test equipment to verify operation of the PAISM05WSH. It is intended as a guide only, and some substitutions are possible.

- One RF signal generator capable of delivering at least +10dBm of output power at the operating frequency
- One RF power sensor capable of handling at least +20dBm of output power at the operating frequency
- One RF power meter capable of measuring up to +20dBm of output power at the operating frequency
- An RF spectrum analyzer that covers the operating frequency range to 3GHz as well as a few harmonics
- A power supply capable of up to 1A at +2.7V to +5.5V
- An optional ammeter for measuring the supply current
- Two 50Ω MCX50 cables
- One SMA 20dB pad
- Network Analyzer to measure small-signal return loss and gain (optional)

Connections and Setup

This section provides a step-by-step guide to operating the PA and testing the device's function. **Do not turn on the DC power or RF signal generators until all connections are made.**

- 1) Connect a DC supply set to +3.6V (through an ammeter if desired) to the VCC and GND terminals on the PA module. **Do not turn on the supply.**
- 2) Connect one RF signal generator to the RFIN MCX50 connector; do not turn on the generator's output. Set the generator for an output frequency of 869MHz at a power level of 0dBm.
- 3) Connect a 20dB pad to the RFOUT MCX50 connector on the PA. This is to prevent overloading of the power sensor and the power meter.
- 4) Connect a power sensor to the 20dB pad.
- 5) Connect the power sensor to a power meter. Set the power meter offset to 20dB and frequency to 869MHz.
- 6) Turn on the DC supply. The supply current should read approximately 69mA.
- 7) Activate the RF generator's output. The power meter should read approximately +27dBm. The supply-current should increase to approximately 550mA.
- 8) Another method for determining gain is by using a Network Analyzer (optional). This has the advantage of displaying gain versus a swept-frequency band, in addition to displaying input and output return loss. Refer to the Network Analyzer manufacturer's user manual for setup details.

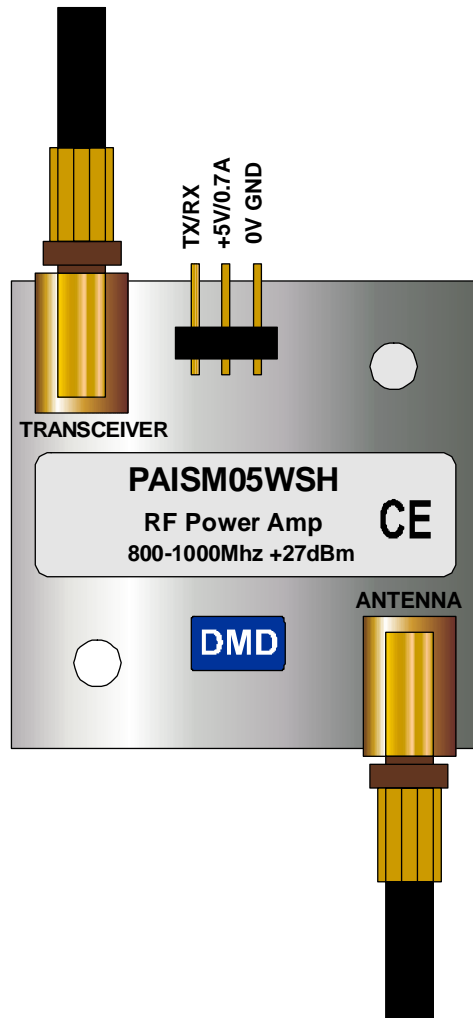



ABSOLUTE MAXIMUM RATINGS

Supply Voltage (Vcc to GND).....	-0.3V to +6.5 V	Storage temperature.....	-20 to +80° C
Voltage on inputs.....	-0.3V to Vcc+0.3V	Operating temperature.....	-20 to +70° C
Input RF level.....	+13dBm (20mW)	Continuous Power Dissipation (TA = +70°C).....	6.4W
Maximum Load Mismatch without Damage, VCC = +2.7V to +3.4V, Any Load Phase Angle, Any Duration.....	20:1	Maximum Load Mismatch without Damage, VCC = +3.4V to +5.5V, Any Load Phase Angle, Any Duration.....	8:1

Stresses beyond those listed under “Absolute Maximum Ratings” may cause permanent damage to the device. These are stress ratings only, and functional operation of the device at these or any other conditions beyond those indicated in the operational sections of the specifications is not implied. Exposure to absolute maximum rating conditions for extended periods may affect device reliability.

VCC = 5V, TA = 25°C, unless otherwise noted.

PARAMETER	SPECIFICATION			UNITS	CONDITION / NOTE
	MIN	TYPICAL	MAX		
DC Electrical Characteristics					
Supply Voltage	2.9	3.6 to 5.0	5.5	V	
Supply Current TX. NO PRFIN.	64	69	71	mA	TX/RX=ON, NO RF INPUT.
Supply Current TX. PRFIN=10dBm	540	550	610	mA	TX/RX=ON, RF OUTPUT +28dBm
Supply Current RX.	10	12	15	uA	TX/RX=OFF (RX active)
Time TX On	100	200	250	uS	
TX/RX Logic High	2.0		Vcc	V	State = TX. PA active
TX/RX Logic Low	0	0	0.2	V	State = RX. PA=Shutdown
TX/RX impedance		10		KΩ	
AC Electrical Characteristics					
Antenna Port Impedance		50		Ω	
Switch Insertion Loss	1.2	1.4	1.6	dBm	
Operational Frequency Range	700		1000	Mhz	
Minimum Output Power	26	27	28	dBm	VCC=5V. PRFIN=10dBm
Power Added Efficiency		47		%	
Power Gain	18	20	22	dB	
Auto Power Ramping-Up		1.6		mW/uS	Maximum slope
Auto Power Ramping-Down		-1.3		mW/uS	Minimum slope
Input VSWR		1.5:1			Relative to input impedance in oper. mode
Maximum Nonharmonic Spurious		-60		dBc	Output Due to load mismatch 6:1 VSWR
Noise Power		-90		dBm	30Khz BW at offset = 45Mhz
Harmonic Suppression.	30	38		dBc	PRFIN=+7dBm
Off-isolation	40	48		dBc	PRFIN= 0dBm. TX/RX=0V.

NOTES

1. Unlicensed radio devices in the European Community Countries are expected to operate in compliance with standards proposed by the European Telecommunications Standard I-ETS 300 220.

TYPICAL OPERATING CHARACTERISTICS INTERNAL AMPLIFIER WITHOUT SWITCH



Note: Typical Insertion Loss Switch = $2 \times 0.7 = 1.4\text{dBm}$

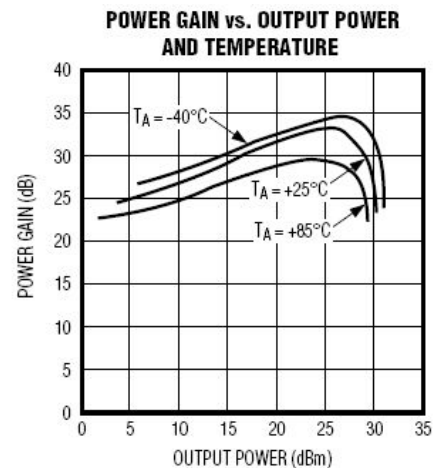
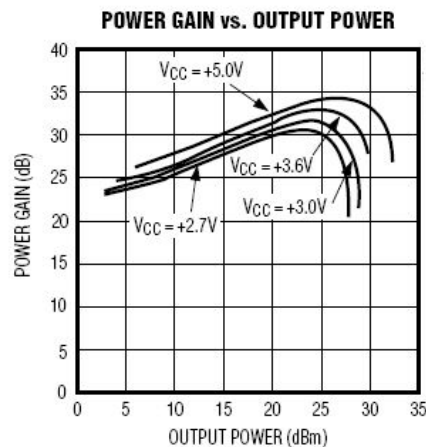
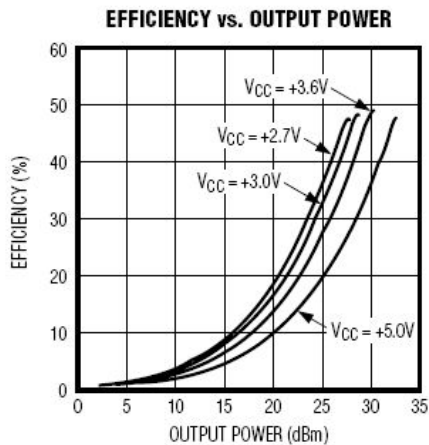
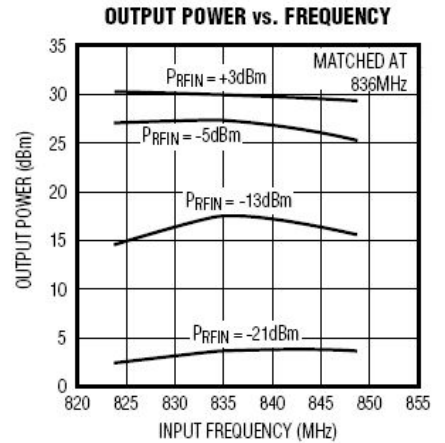
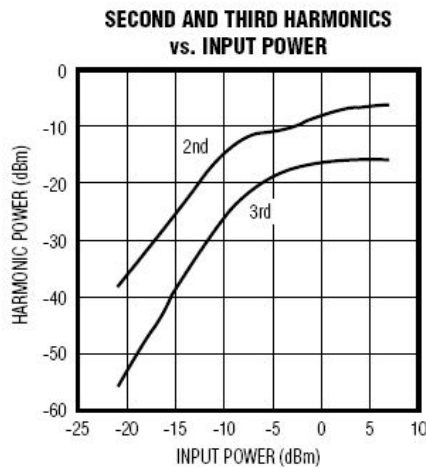
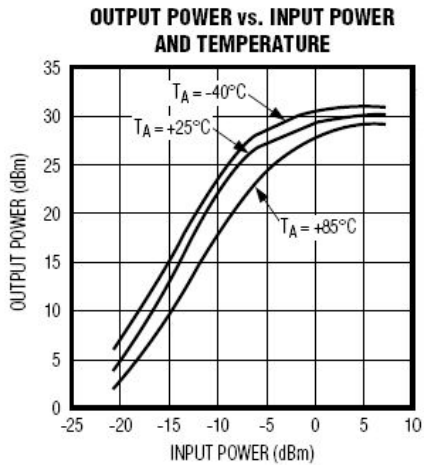
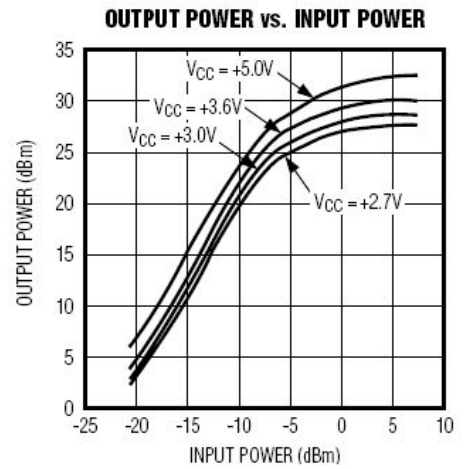
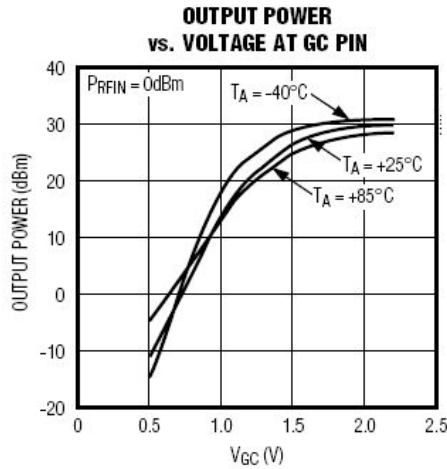
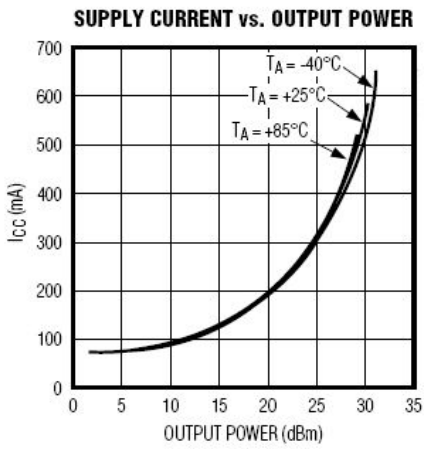

Digital Micro Devices

Wireless Systems

C/ Federico Garcia Lorca, 5
46136 Museros (Valencia)
Spain
Europe

Telf. 34 96 1450346

Fax. 34 96 1450484

Web: www.dmd.es

www.dmdopen.com

Emails: dmd@dmd.es, ventas@dmd.es, tecnico@dmd.es

©Digital Micro Devices 2007, 2008.

Las marcas mencionadas lo son a título informativo, siendo propiedad de sus legales registradores.

Digital Micro Devices (DMD) no ofrece ninguna garantía sobre el uso de este producto a excepción de las garantías estándar de la compañía que se detallan en DMD términos y condiciones localizadas en la página Web de DMD.

DMD no asume ninguna responsabilidad por los errores que puedan aparecer en este documento y se reserva el derecho de cambio de los dispositivos ó las especificaciones que se detallan en cualquier momento y sin previo aviso ni tiene ningún compromiso para actualizar esta información. No se otorgan licencias ni patentes ó cualquier otra propiedad intelectual de DMD entorno a la venta de los productos de DMD, expresamente ó por implicación. Los productos de DMD no están autorizados para el uso como componentes críticos en equipos en los que dependa la vida de las personas. DMD declina toda responsabilidad por el uso que el usuario haga de este módulo.